

# PHILIPS

---

## X 1210

## Monodisk

## Volume 2 : Operation



data systems

# VOLUME 2 CHAPTER 1

## OPERATION

### CONTENTS

<u>Paragraph</u>		<u>Page Nr.</u>
1	<u>OPERATION</u>	2.1.1
1.1.	<u>OPERATOR PANEL</u>	2.1.1
1.1.1	START/STOP PUSHBUTTON	2.1.1
1.1.2	CARTRIDGE EXCHANGE LAMP	2.1.1
1.1.3	FAULT LAMP	2.1.1
1.2	<u>OPERATION</u>	2.1.2
1.2.1	LOADING A CARTRIDGE	2.1.2
1.2.2	CARTRIDGE REMOVAL	2.1.2
1.2.3	TO START THE X1210	2.1.4
1.2.4	FAILURE TO START	2.1.4
1.2.5	FAULT INDICATION	2.1.4
1.2.6	TO STOP THE X1210	2.1.4

## I L L U S T R A T I O N S

<u>Figure</u>		<u>Page Nr.</u>
2.1	FRONT PANEL CONTROLS	2.1.1
2.2.	CARTRIDGE EXCHANGE SEQUENCE	2.1.3
2.3	START/STOP CONTROL AND FAULT INDICATION	2.1.5

1

## OPERATION

1.1

### OPERATOR PANEL

All the X1210 operator controls are supported on the front panel. They comprise a start/stop pushbutton, a cartridge exchange lamp and a fault indicator lamp.

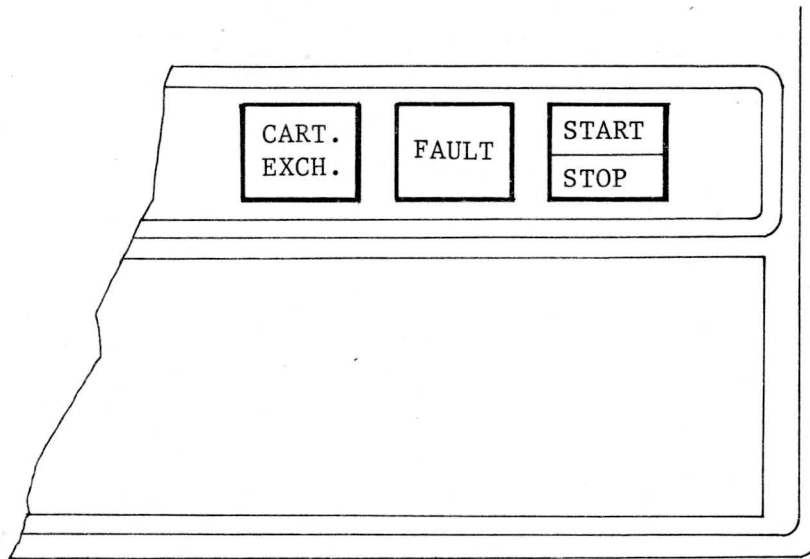

Fig. 2.1 - Front Panel Controls

1.1.1

#### START/STOP PUSHBUTTON

This consists of a spring loaded alternate action pushbutton switch, integral with a green indicator lamp. This lamp lights when the X1210 is started and remains lit during normal operation. When the button is pressed to stop the unit, the lamp extinguishes.

1.1.2

#### CARTRIDGE EXCHANGE LAMP

This lamp lights (green) when the power supplies haven been connected to the X1210 and when it is safe to remove or install a cartridge.

1.1.3

#### FAULT LAMP

This lamp lights (red) when an unsafe condition arises during machine operation and remains lit when the X1210 is stopped with a fault condition.

Note: While the power supplies are on, one of these three lamps is lit.

## 1.2 OPERATION

### 1.2.1 LOADING A CARTRIDGE

Before implementing the cartridge exchange procedure, check that the only lamp lit on the X1210 front panel is the cartridge exchange lamp. If this lamp is lit, proceed as follows:

- (a) Slide the X1210 from the rack unit until further withdrawal is limited by the slide stops.
- (b) Check the cartridge holder locking ring is fully anti-clockwise.
- (c) Holding the cartridge by its handle, locate the cartridge into the holder and press gently into position.
- (d) The cartridge can then be locked into the holder by rotating the locking ring fully clockwise.
- (e) The cartridge handle must be folded down into the recess on the cartridge top surface before pushing the X1210 back into position in the rack unit.

### 1.2.2 CARTRIDGE REMOVAL

Before implementing the cartridge removal procedure, check that the cartridge exchange lamp is lit.

If this lamp is lit proceed as follows:

- (a) Pull the X1210 from the rack unit until further withdrawal is limited by the slide stops.
- (b) Pivot the cartridge handle out of its recess and push the handle backwards (towards the rack unit) until it stops.
- (c) Return cartridge handle back to the vertical position.
- (d) Release the cartridge from its holder by turning the locking ring fully anti-clockwise and lift the cartridge from the X1210.

### REMOVING A CARTRIDGE

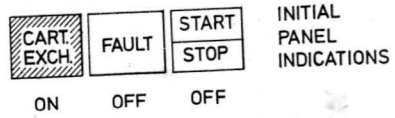

#### OPERATOR ACTIONS

- FULLY WITHDRAW X1210 FROM RACK
- PIVOT CARTRIDGE HANDLE FULLY TOWARDS RACK

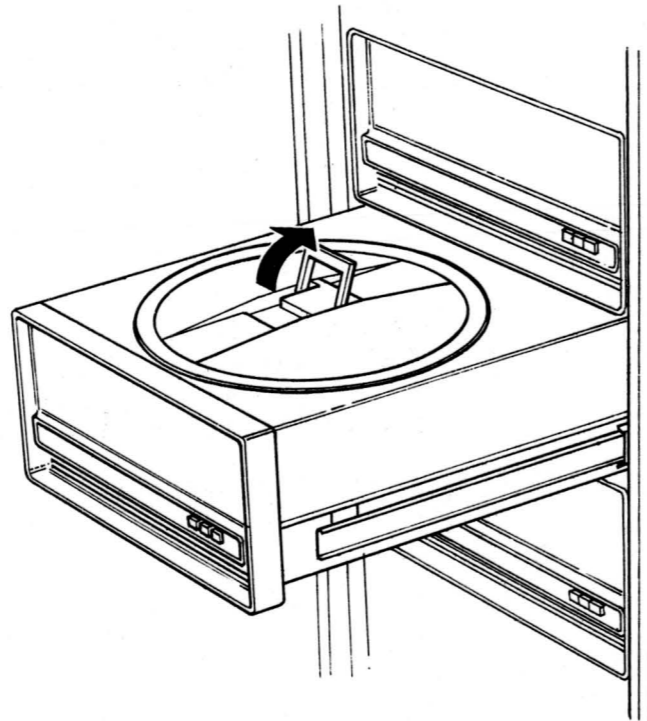

- ROTATE LOCKING RING FULLY ANTI-CLOCKWISE
- LIFT CARTRIDGE FROM X1210

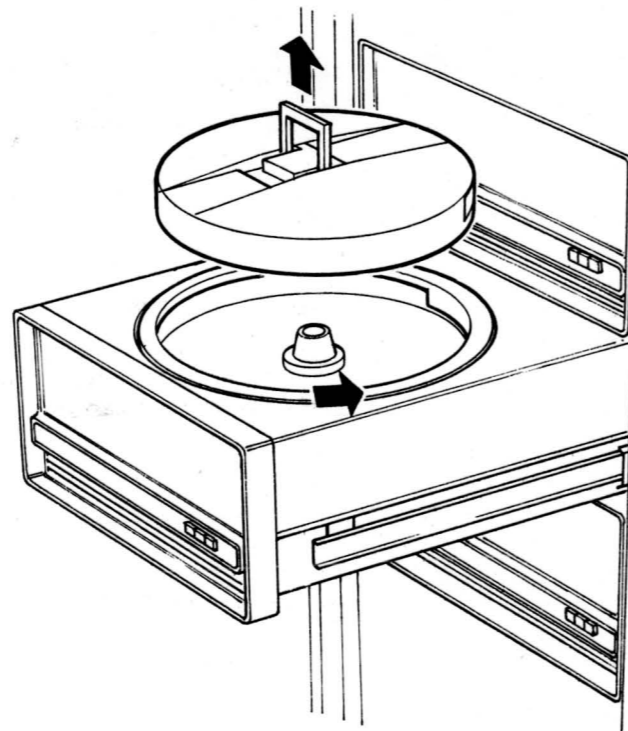

REPLACEMENT CARTRIDGE CAN NOW BE FITTED

### FITTING A CARTRIDGE

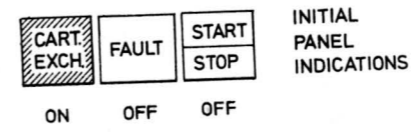

#### OPERATOR ACTIONS

- FULLY WITHDRAW X1210 FROM RACK
- IF A CARTRIDGE IS FITTED, SEE REMOVAL INSTRUCTIONS
- IF A CARTRIDGE IS NOT FITTED, CHECK LOCKING RING IS FULLY ANTI-CLOCKWISE

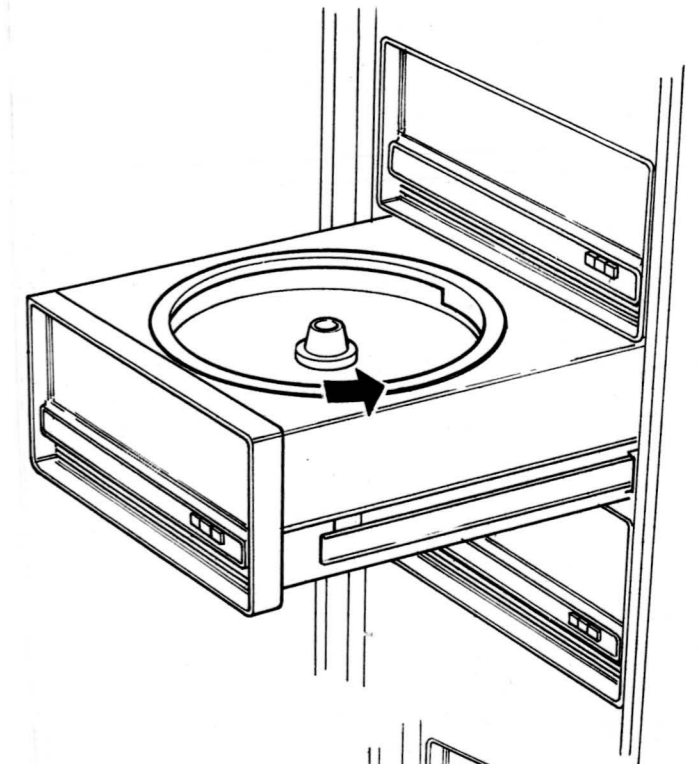

- FIT CARTRIDGE INTO X1210
- ROTATE LOCKING RING FULLY CLOCKWISE
- FOLD CARTRIDGE HANDLE FORWARD INTO RECESS
- PUSH X1210 BACK INTO THE RACK

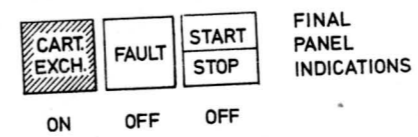
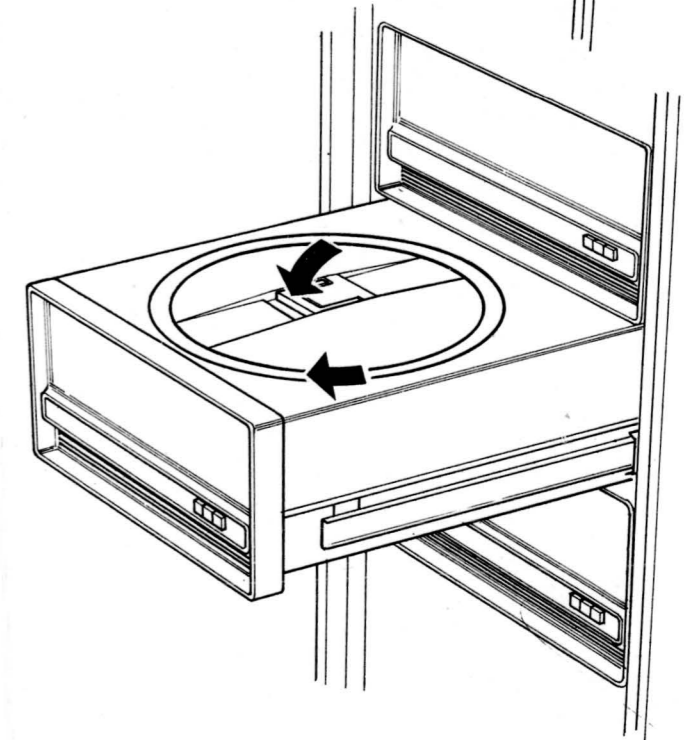

X1210 CAN NOW BE STARTED

FIGURE 2.2 CARTRIDGE EXCHANGE SEQUENCE

1.2.3 TO START THE X1210

If the cartridge has been correctly fitted into the holder and locked into position and the X1210 pushed completely back into the rack, the X1210 will start when the start/stop button is pressed.

When the X1210 is started, the cartridge exchange lamp extinguishes and the start/stop lamp lights.

1.2.4 FAILURE TO START

If the X1210 fails to start (cartridge exchange lamp remains lit, fault lamp lights and start/stop lamp remains extinguished) press the start/stop button twice. If the unit still fails to start, check that the cartridge loading sequence has been correctly performed.

Should the cartridge exchange sequence prove to have been correctly performed and the X1210 still fails to start, call the customer engineer.

1.2.5 FAULT INDICATION

If the fault lamp lights while the X1210 is operating, the unit should be stopped by pressing the start/stop button.

When stopped, the start/stop lamp extinguishes, the fault lamp remains lit and the cartridge exchange lamp lights.

The X1210 should then be re-started and in the case of a temporary fault condition, the start/stop indicator will light and the cartridge exchange lamp and fault lamp extinguish.

If the fault condition is a permanent one, approximately 10 seconds after pressing the start button, the fault lamp will again light.

1.2.6 TO STOP THE X1210

Press the start/stop button. The start/stop lamp will extinguish and the cartridge exchange lamp lights.

TO START X1210

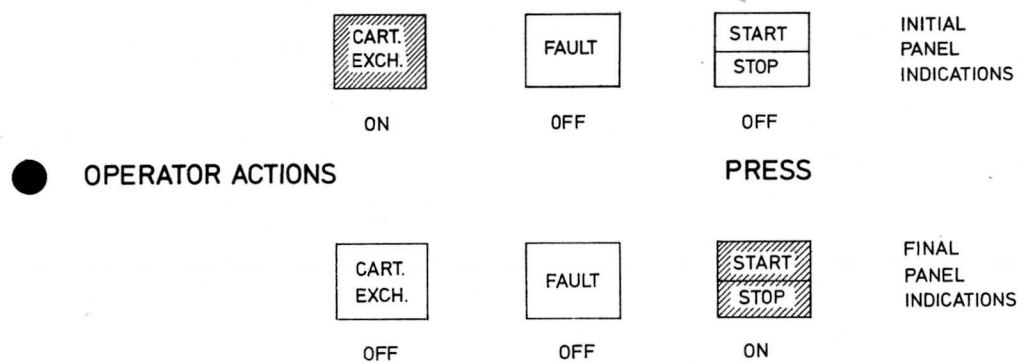

RESULT — X1210 STARTED

FAILURE TO START (CASE 3)

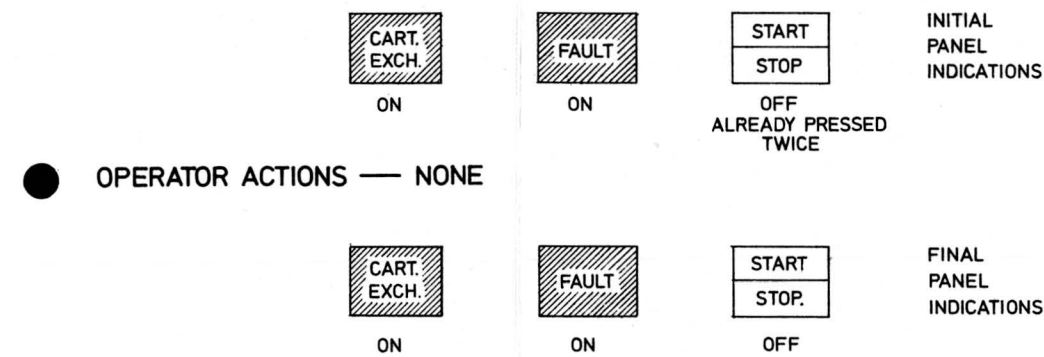

RESULT — X1210 FAULTY — REQUIRES SERVICING

FAILURE TO START (CASE 1)

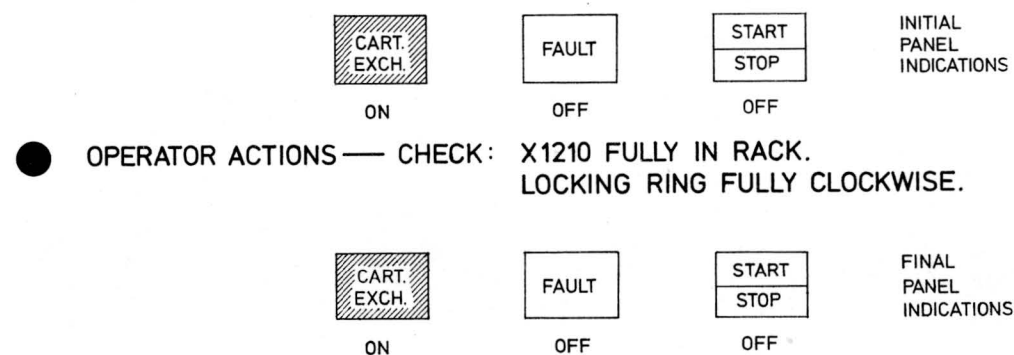

RESULT — REPEAT START PROCEDURE

FAULT INDICATION DURING OPERATION

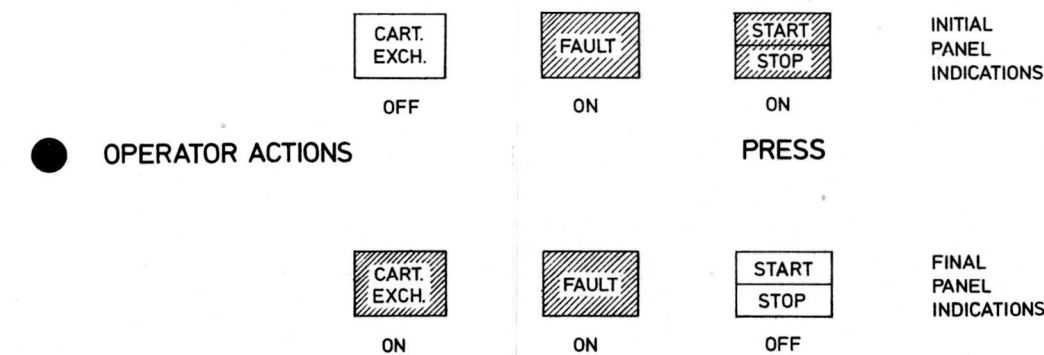

RESULT — X1210 STOPPED WITH FAULT — REQUIRES SERVICING

FAILURE TO START (CASE 2)

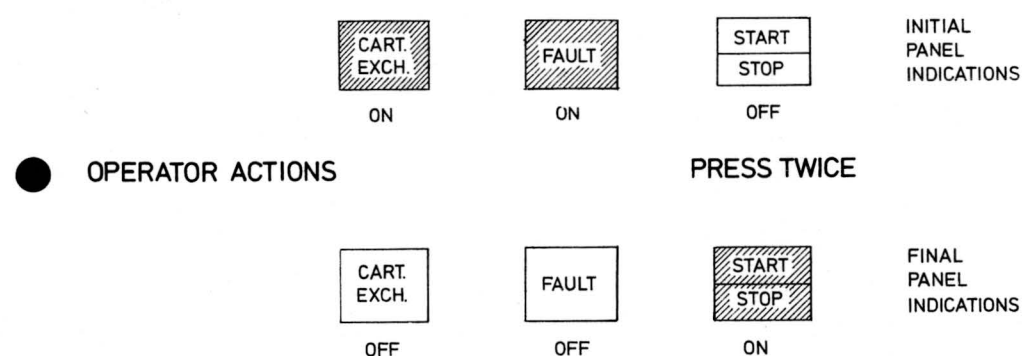

RESULT — X1210 STARTED

TO STOP X1210

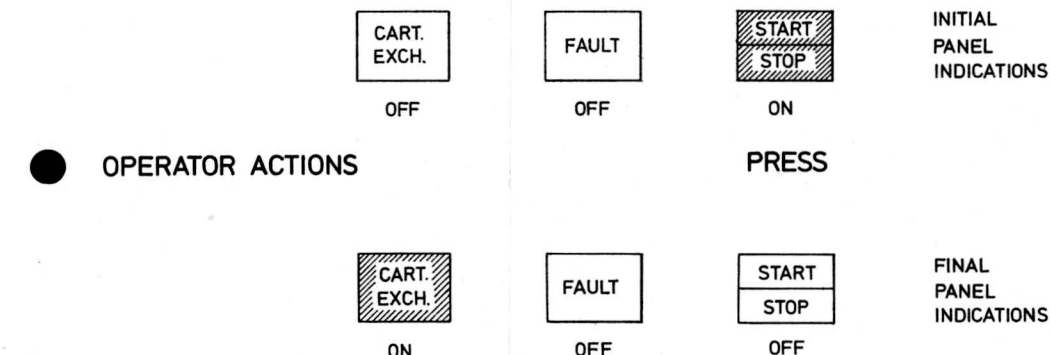

RESULT — X1210 NOW STOPPED

FIGURE 2.3 START/STOP CONTROL AND FAULT INDICATION

VOLUME 2 CHAPTER 2  
OPERATOR MAINTENANCE

CONTENTS

<u>Paragraph</u>		<u>Page Nr.</u>
2	<u>OPERATOR MAINTENANCE</u>	2.2.1
2.1	<u>CARTRIDGE RECOVERY PROCEDURE</u>	2.2.1
2.1.1	POWER SUPPLIES FAILURE	2.2.1
2.1.2	RETRACTING THE POSITIONING MECHANISM BY HAND	2.2.1
2.1.3	RELEASE THE LOCKING RING MECHANISM	2.2.3

ILLUSTRATIONS

<u>Figure</u>		<u>Page Nr.</u>
2.4	SERVICING POSITION	2.2.ii
2.5	MANUAL RETRACTION OF POSITIONING MECHANISM	2.2.2
2.6	RELEASING THE LOCKING RING MECHANISM	2.2.4

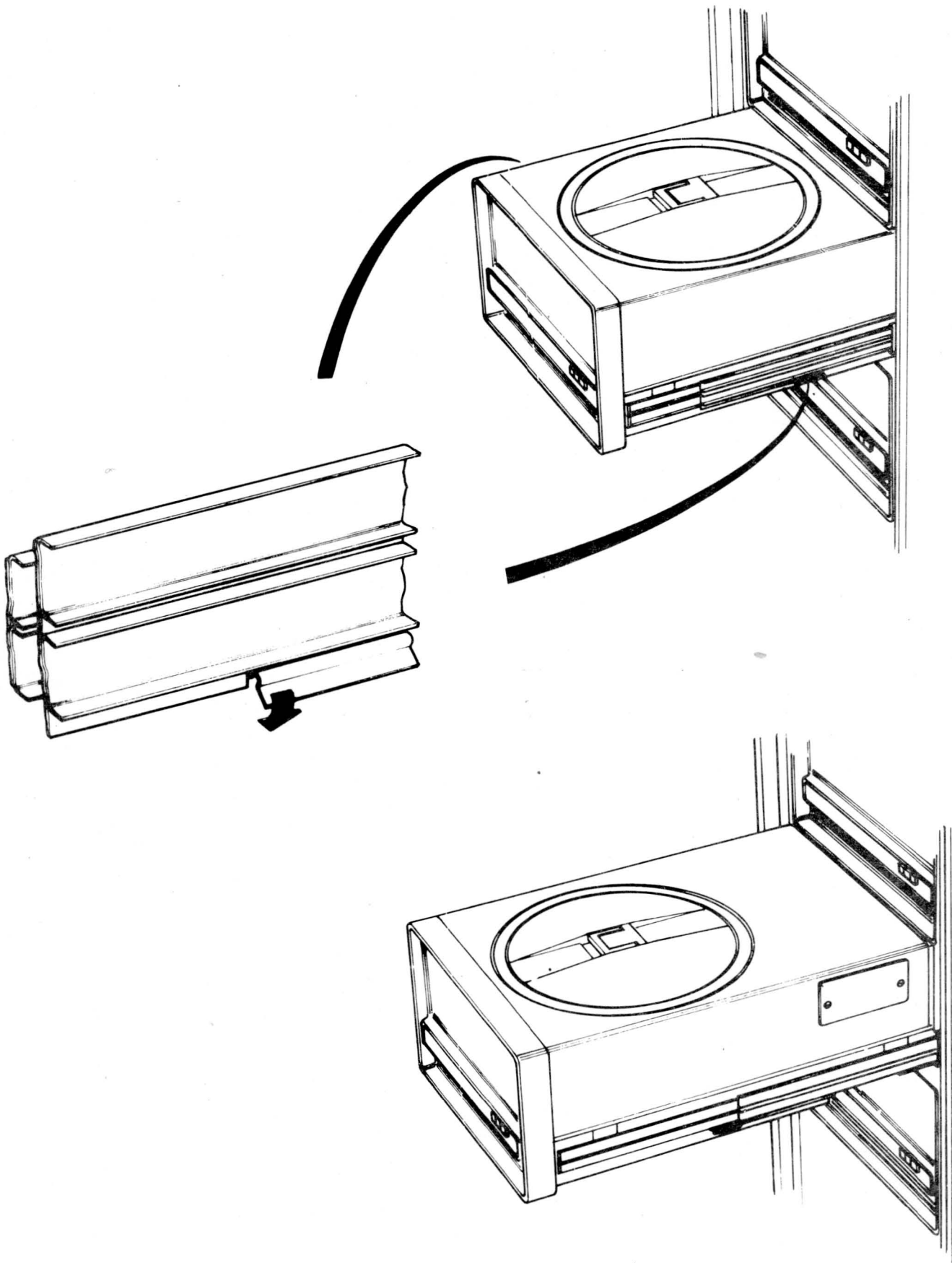

**FIGURE 2.4 SERVICING POSITION**

2

OPERATOR MAINTENANCE

2.1

INTRODUCTION

This part contains procedures for scheduled preventive maintenance on an hours used basis.

Even though the unit is operating satisfactorily, the scheduled preventive maintenance should be performed.

The elapsed time meter, behind the grate assembly in front of the machine, should be used to check the intervals in which preventive maintenance will be performed.

Cartridge

If the cartridge is out of the unit, be sure that the shutter is always closed, so dust is not allowed to enter the cartridge.

2.2

PREVENTIVE MAINTENANCE PROCEDURES

500 Hour Maintenance

2.2.1

REPLACEMENT OF FILTER, FRONT PLATE ASSY (Fig:2.5)

- (a) Unscrew the two fasteners (1)
- (b) Remove the grate assembly (2)
- (c) Change the filter (3)
- (d) Replace the grate assembly and fix in position with the fasteners (1)

2.2.2 CLEANING OF THE CARTRIDGE HOLDER (Fig. 2:6)

(a) Remove the cartridge

(b) Carefully clean the cartridge holder (1), so that the cartridge holder is free from dust and all kind of dirt.

2.2.2.1 Clean Spindle

Wipe the spindle carefully with a Scotch wiper damped with isopropanol.

Caution: Never touch the spindle with your bare fingers and use only isopropanol to clean the spindle.

2.2.3 PREVENTIVE MAINTENANCE REQUIREMENTS

1 screwdriver (4,3 x 150)	2622 150 11006
1 front filter	5122 228 31100
Scotch wipers	5122 010 20911
Isopropanol	1322 505 69201

## 2.3 CARTRIDGE RECOVERY PROCEDURE

### 2.3.1 POWER SUPPLIES FAILURE

Should prolonged failure of the X1210 power supplies occur, the cartridge can be removed from the unit. This action will minimise the possibility of dirt or dust particles fouling the monodisk cartridge interior. Failure of the power supplies will be indicated by all X1210 lamp extinguishing.

Removal of the cartridge in the normal way is not possible under these conditions due to:

- (a) The read/write heads being positioned inside the cartridge.
- (b) The cartridge holder locking mechanism prevents rotation of the locking ring when the locking mechanism electrical supply is de-energized.

Thus, to remove the cartridge under these conditions, the head positioning mechanism must be manually retracted from the cartridge and a special technique employed to free the locking ring.

### 2.3.2 RETRACTING THE POSITIONING MECHANISM BY HAND

Access to the head positioning mechanism is gained via the detachable panel on the right hand side of the X1210 (when viewed from front panel). To remove this panel the X1210 must first be withdrawn to the servicing positions as follows:

- (a) Withdraw the X1210 to the cartridge exchange position.
- (b) Simultaneously unlatch both detent levers on the rack unit slides whilst withdrawing the X1210 fully clear of the rack unit (see fig. 2:4).

Caution: Turn off X1210 power supply switch.

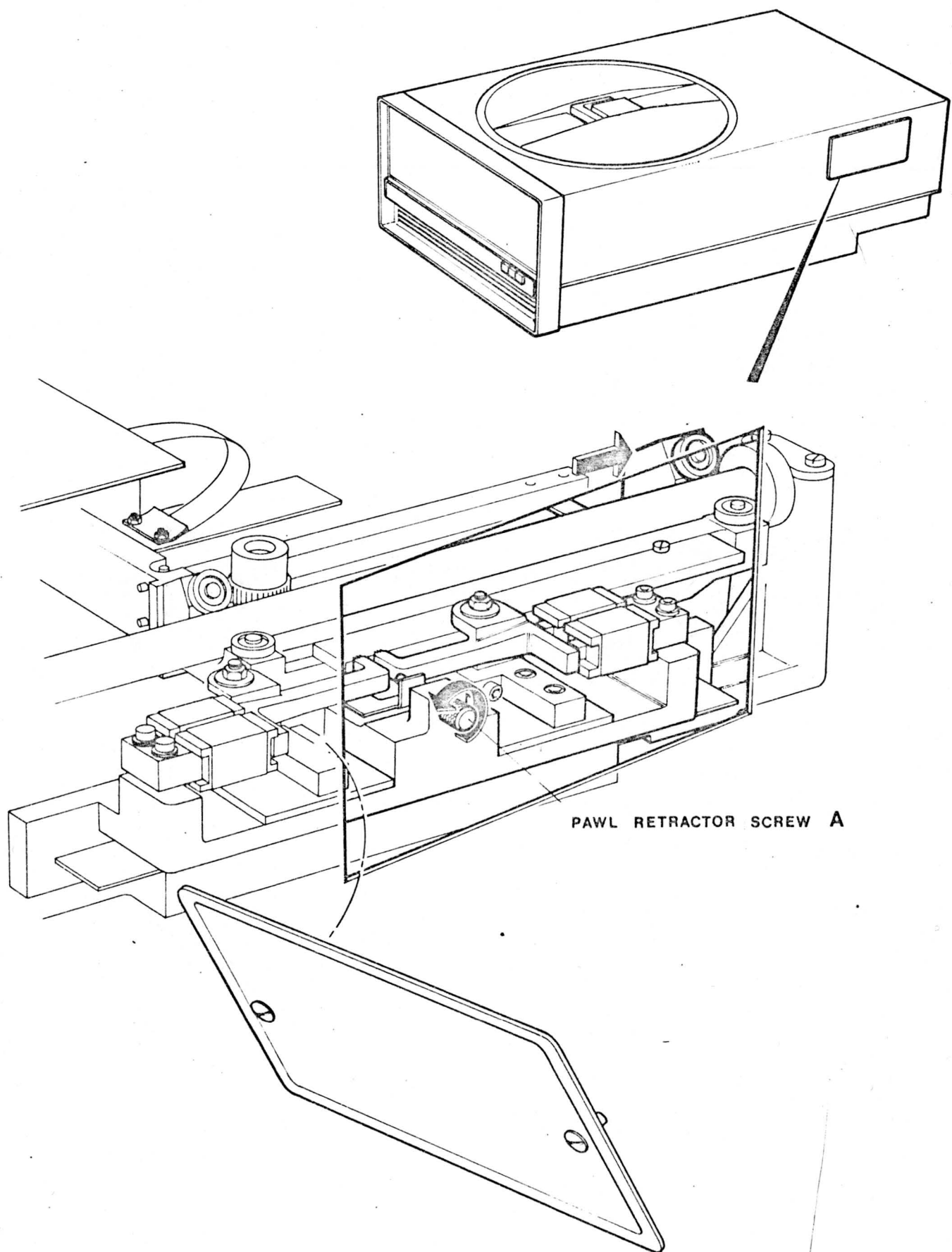

FIGURE 2.5 MANUAL RETRACTION OF POSITIONING MECHANISM

Remove the two screws retaining the access panel in position. The positioning mechanism cannot be retracted until it has been released from its detent mechanism. With reference to figure 2.7, this is effected by turning the detent mechanism pawl retractor screw (A), in an anti-clockwise direction until no further rotation of the screw can be made. The positioning mechanism can then be retracted by inserting the hand through the access panel, over the detent mechanism and sliding the positioner to its end stop at the rear end of the X1210.

### 2.3.3

#### RELEASING THE LOCKING RING MECHANISM

The technique employed to free the locking assembly when the supplies have failed requires the use of a length of mild steel wire about 1/32 inch diameter (1 mm). A wire paper clip straightened out is ideal for this purpose. With reference to fig. 2.8 insert the wire into the hole on the locking ring. This hole is about 1/16 inch diameter (2 mm) and is positioned on the front top surface of the locking, just right of centre.

Push the wire about one inch (25 mm) down into the hole whilst simultaneously rotating the locking ring anti-clockwise approximately 1/2 inch (12 mm). At this point the wire will drop further into the hole and if the ring is rotated further, the wire will foul the locking mechanism preventing further rotation of the locking ring. At this point the wire must be completely withdrawn. The locking ring can then be rotated fully anti-clockwise and the monodisk cartridge removed from the X1210.

When the cartridge has been removed, turn the detent mechanism pawl retractor screw fully clockwise until the positioning mechanism is locked in the fully retracted position. Replace the positioning mechanism access panel (two screws) and push the X1210 back into the rack unit.

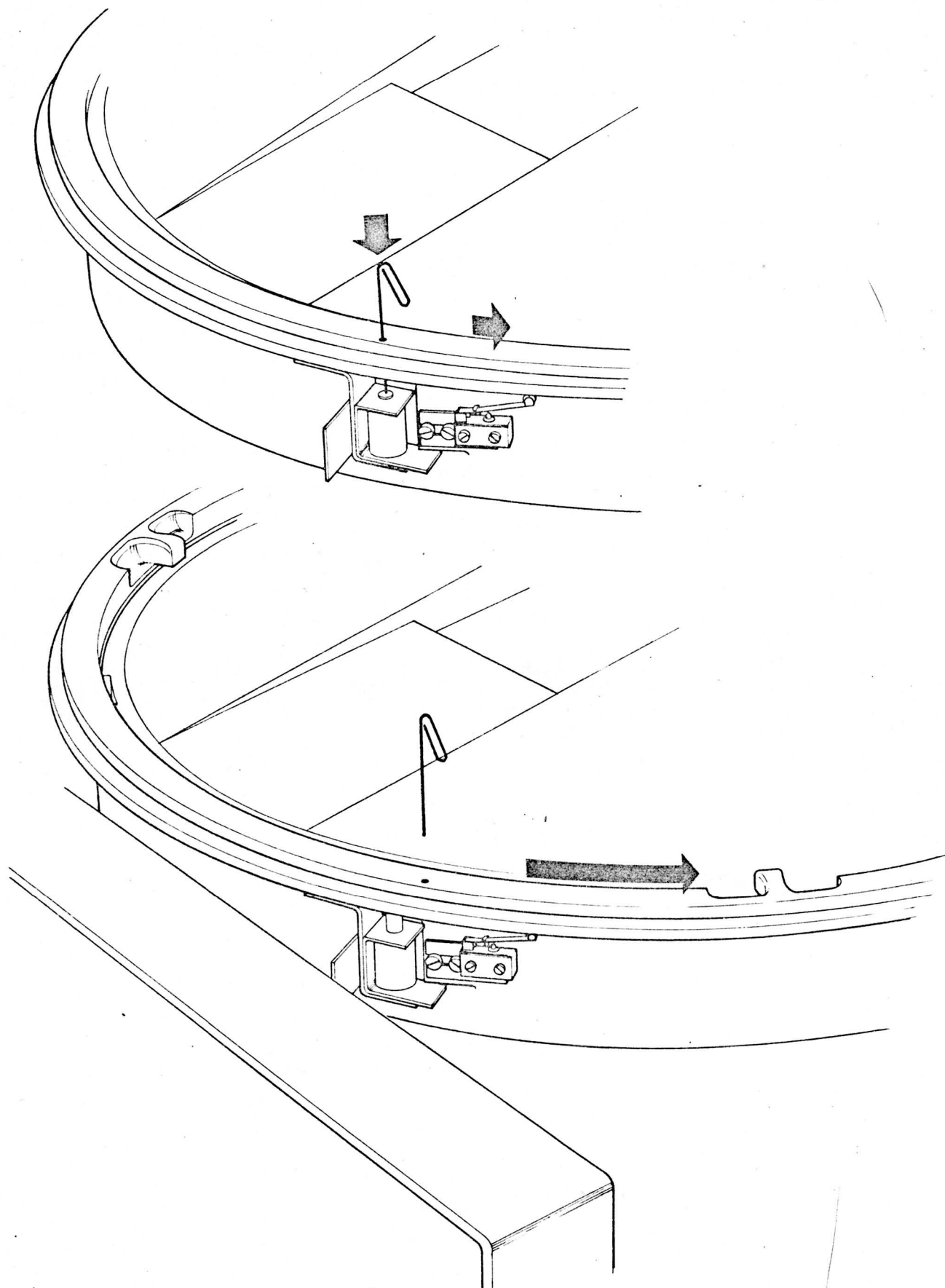

FIGURE 2.6 RELEASING THE LOCKING RING MECHANISM